

SELECTORIZED STRENGTH TRAINING EQUIPMENT

SU15 Pectoral Fly

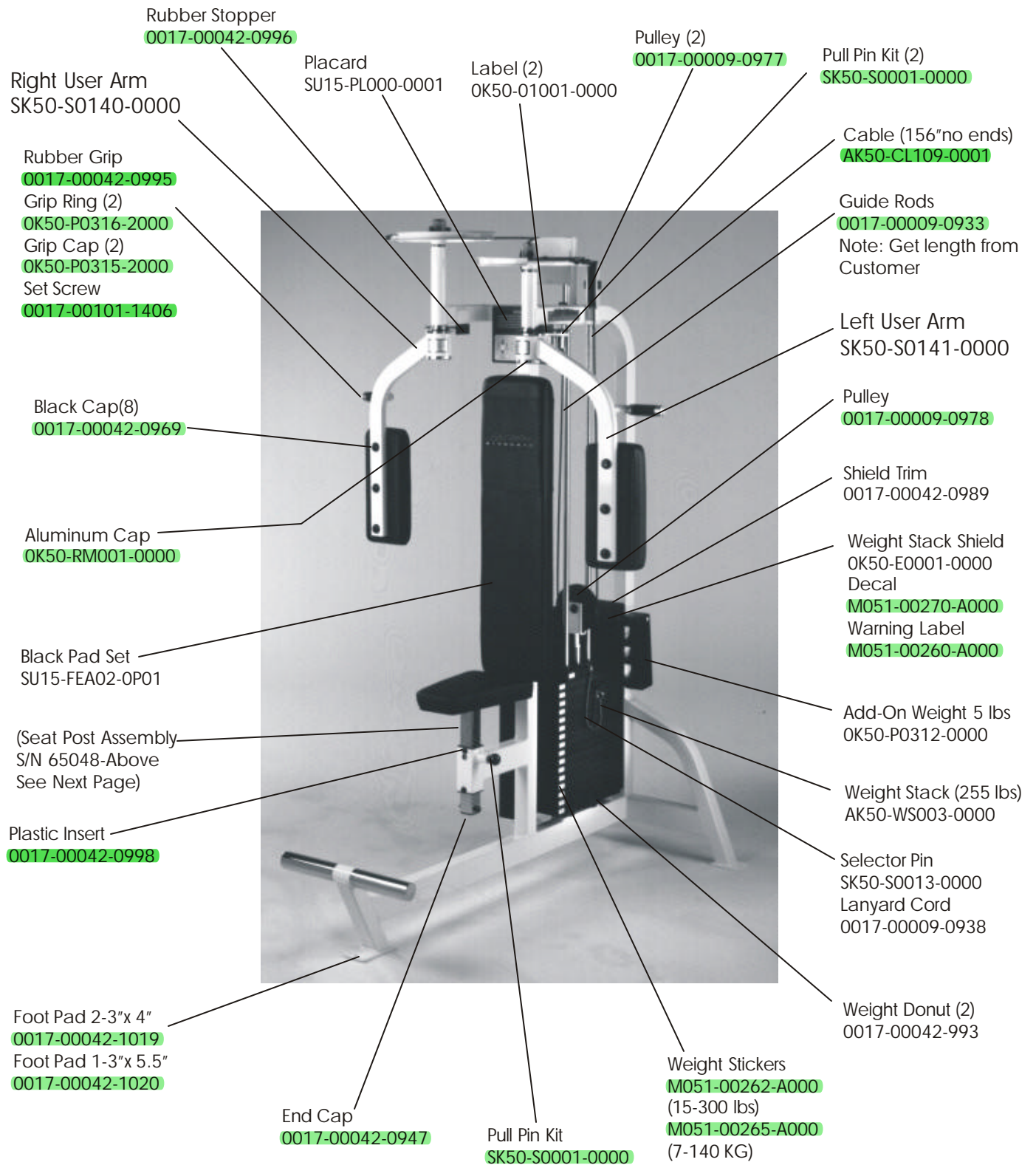

SELECTORIZED STRENGTH TRAINING EQUIPMENT

SU15 Seat Post Assembly - S/N65048-Above

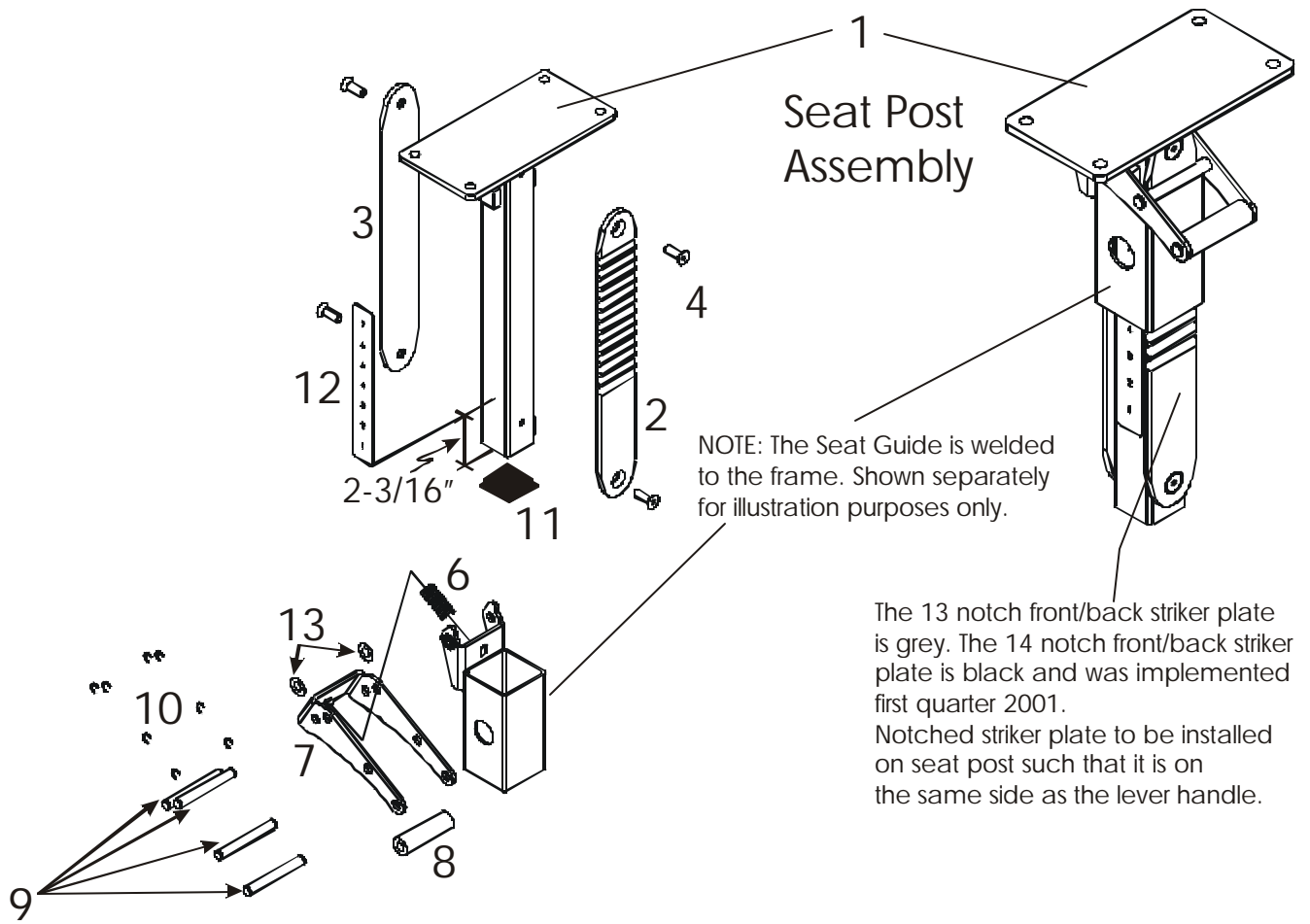

BILL OF MATERIALS			
Item No.	Qty.	Part Number	Description
1	1	AK50-S0028-0000	Seat post assembly
2	1	OK50-P0547-0000	Front striker plate (~4 notch)
3	1	OK50-P0548-0000	Back striker plate
4	4	0017-00101-1655	5/16" x 24 flat bolt
6	1	0017-00009-1079	Spring
7	1	OK50-P0550-0000	Lever release
8	1	0017-00042-1089	Rubber grip
9	4	OK50-P0551-0000	Grooved pin
10	8	0017-00100-0190	Retaining clips
11	1	0017-00042-0944	1-1/2" x 1-1/2" End cap
12	1	M051-00303-A000	Number strip
13	2	0017-00104-0373	Nylon washer